

Non-injected body

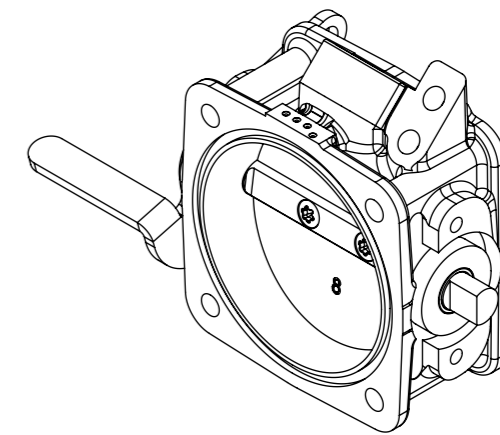
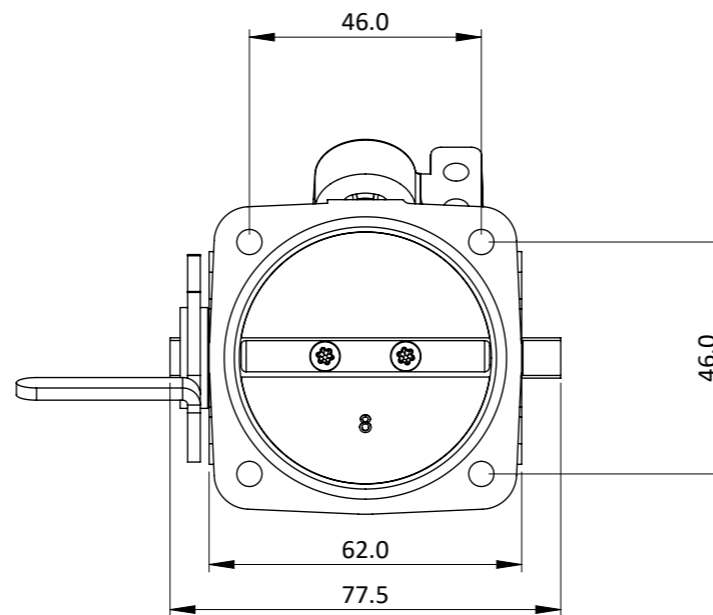

Injected body

The type SFS body fits the same flanges as the rest of the popular SF range and is available with or without an injector pocket. It is an extremely compact body allowing very long air horns to be used within a given system length.

Sizes are; 40, 42, 45, 48 and 50mm bores.

Bodies come with 'O' rings and fitting kits. Can be fitted with right hand linkage (when ordering 1 body), or standard in-line interconnecting links when ordering a number of bodies.

Operating data; Spindle rotation: 82 degrees. Torque per spindle at WOT: 110 - 120 N-mm which gives a tangential pull of 2.9 - 3.1 N on long arm of standard lever.

Option of 310 N-mm springs available.

Other items; Fuel rails, fuel rail mountings, quadrant throttle mechanism, range of air horns (bellmouths, trumpets, stacks), throttle potentiometers.

Note that the SFS body does not come with a lever as standard

Frame: 1 of 1	
Version: 4	
Tel 01746 768810	© JENVEY DYNAMICS LTD. 2024
Web WWW.JENVEY.CO.UK	