

CKPG04 - Citroen C2 - ST45 Taper Kit

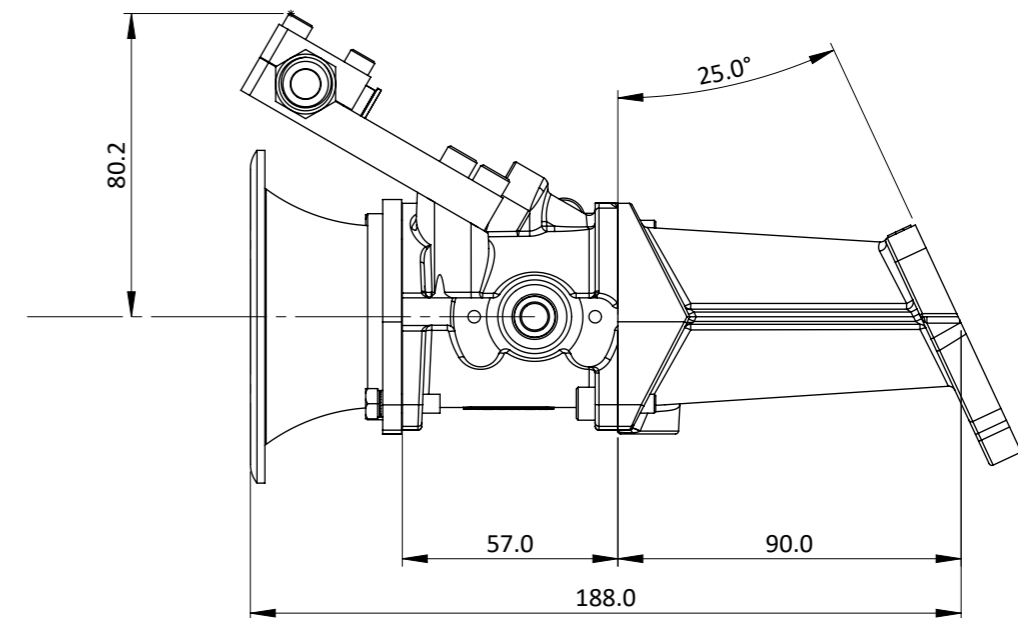

Engineered to win

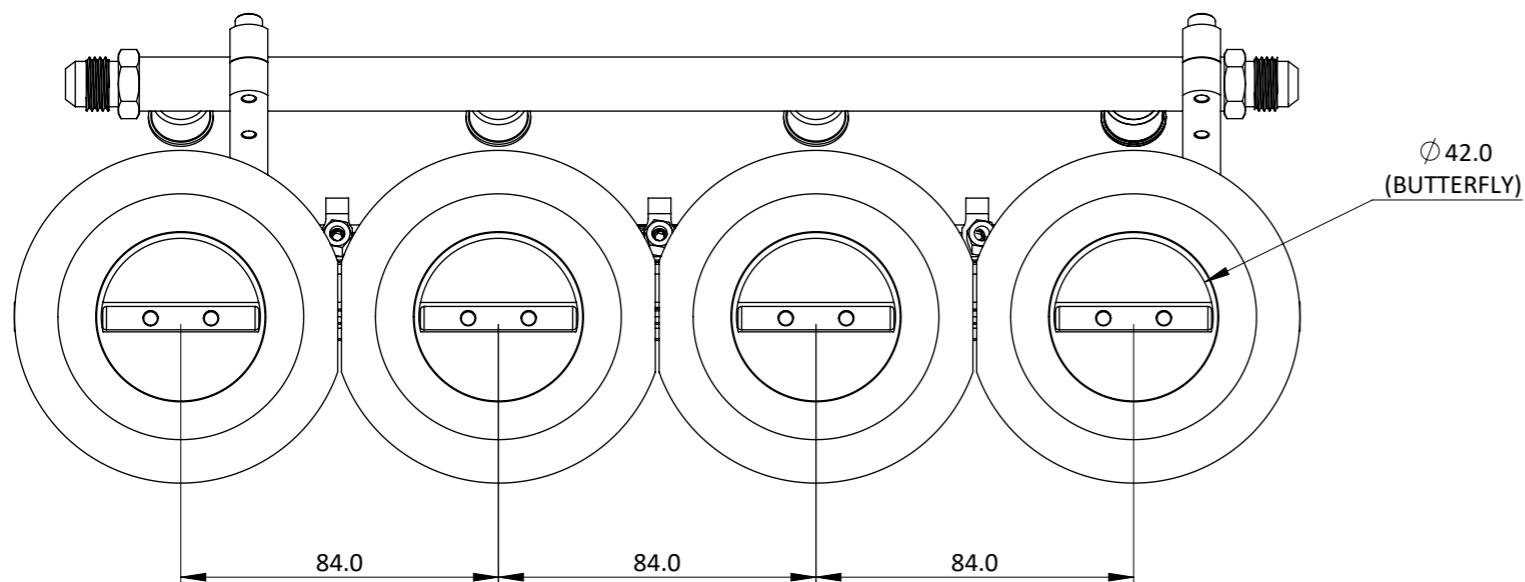
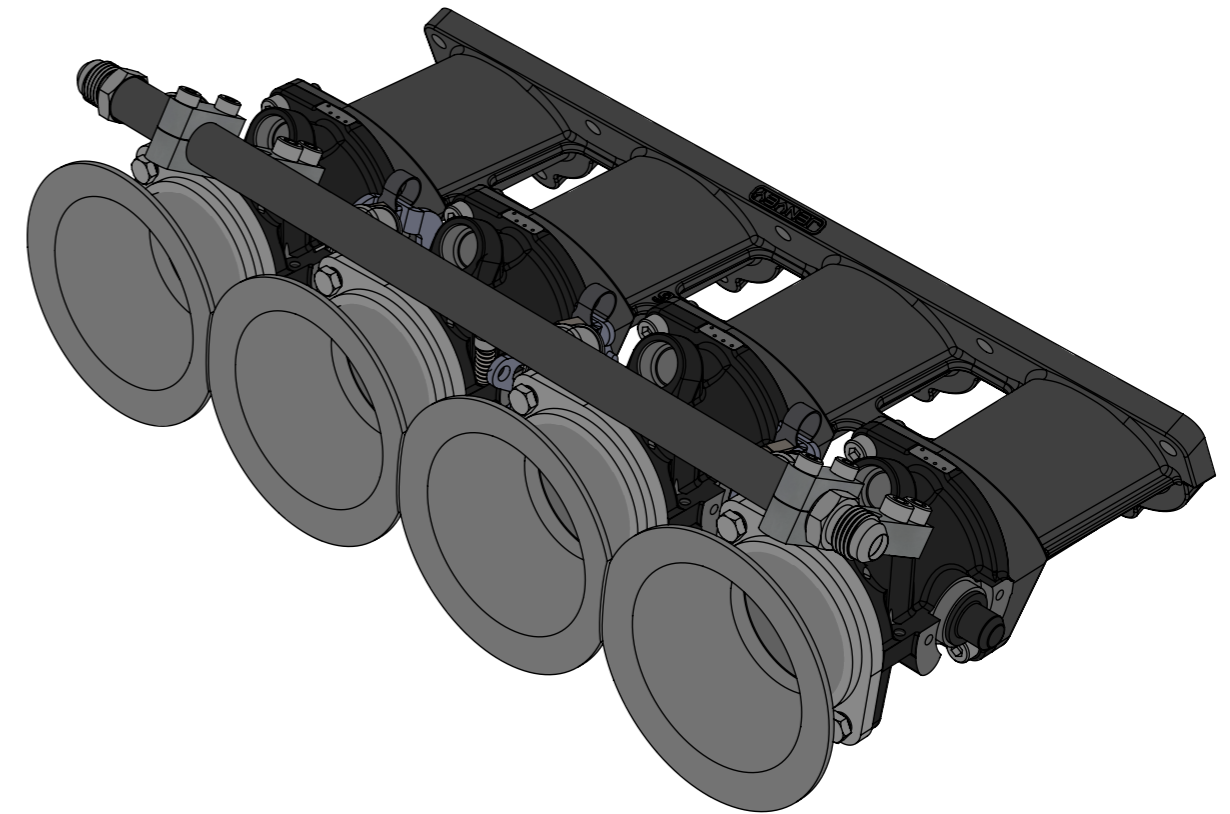
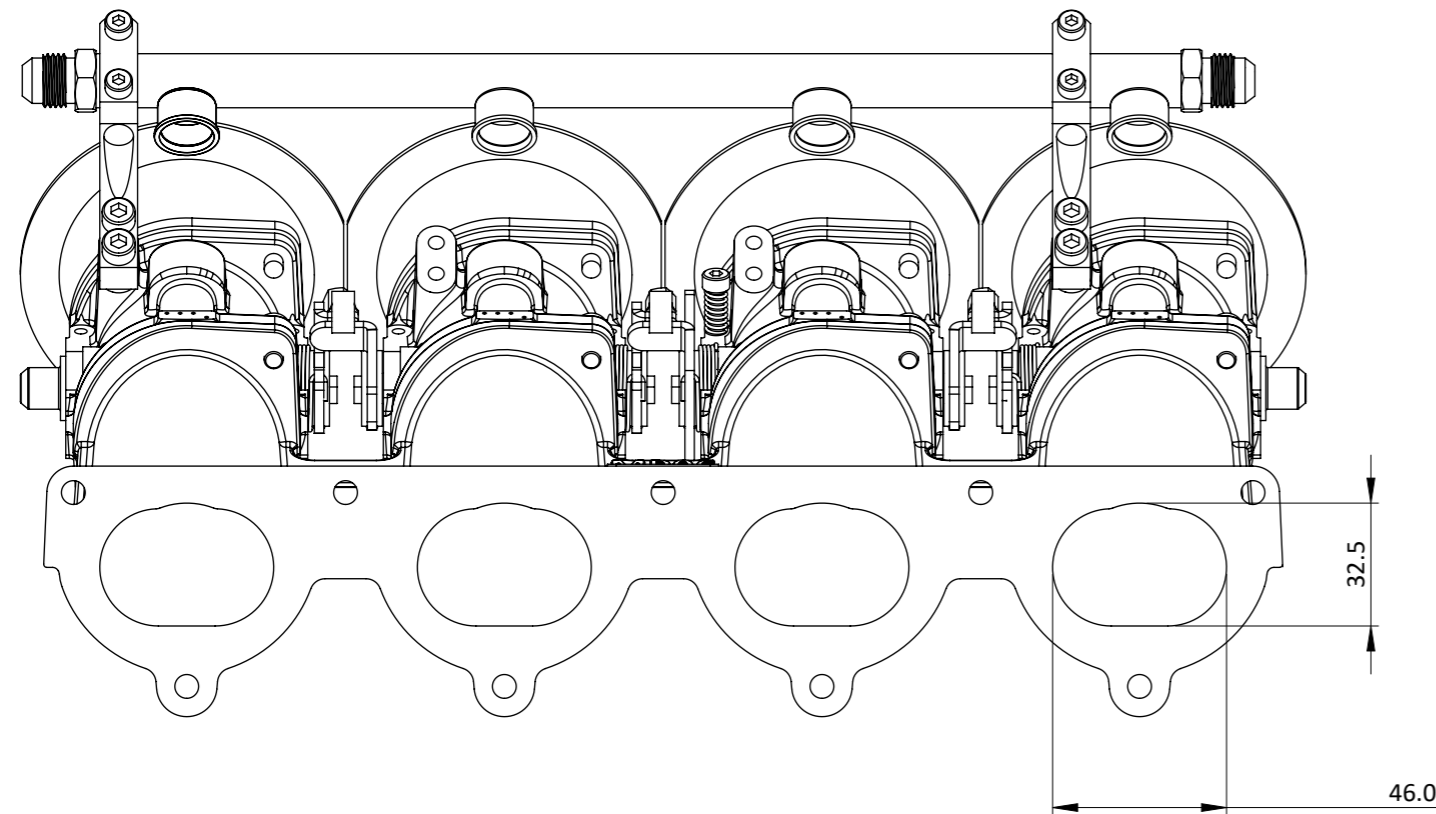

The Jenvey Dynamics tapered CKPG04 kit promises enhanced performance and better throttle control for the TU5JP4 & TU5JP4s engine as found in the VTS, VTR & GT models. This kit contains, an inlet manifold, four ST45 tapered throttle bodies (42mm butterfly), fuel rail, fuel rail mounts and 40mm long airhorns. Where space is available 90mm airhorns further improve performance.

Frame: 1 of 1	
Version: 2	
Tel 01746 768810	© JENVEY DYNAMICS LTD. 2024
Web WWW.JENVEY.CO.UK	