

# CKJR05-TD - Jaguar XK6 TD45 Heritage throttle body kit

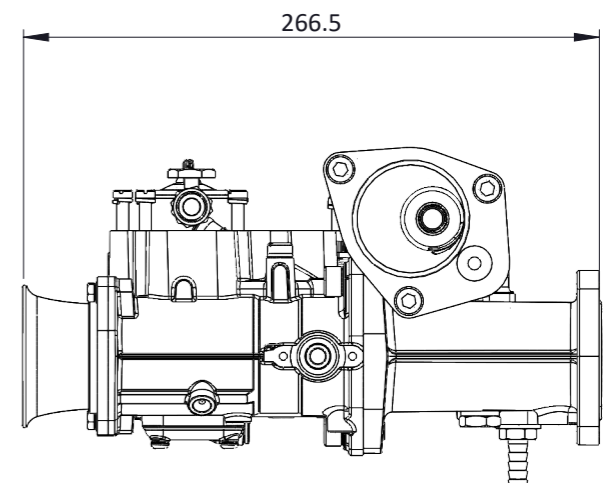

Engineered to win

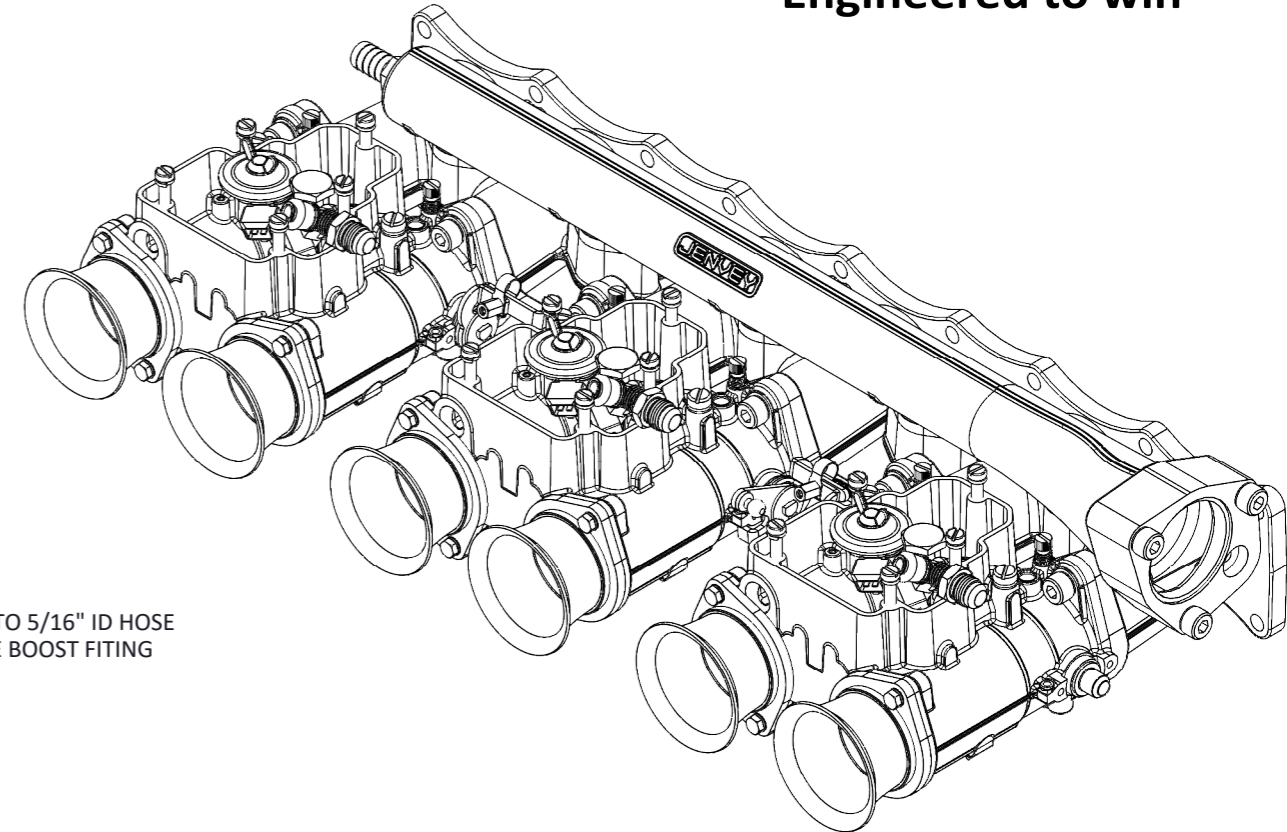
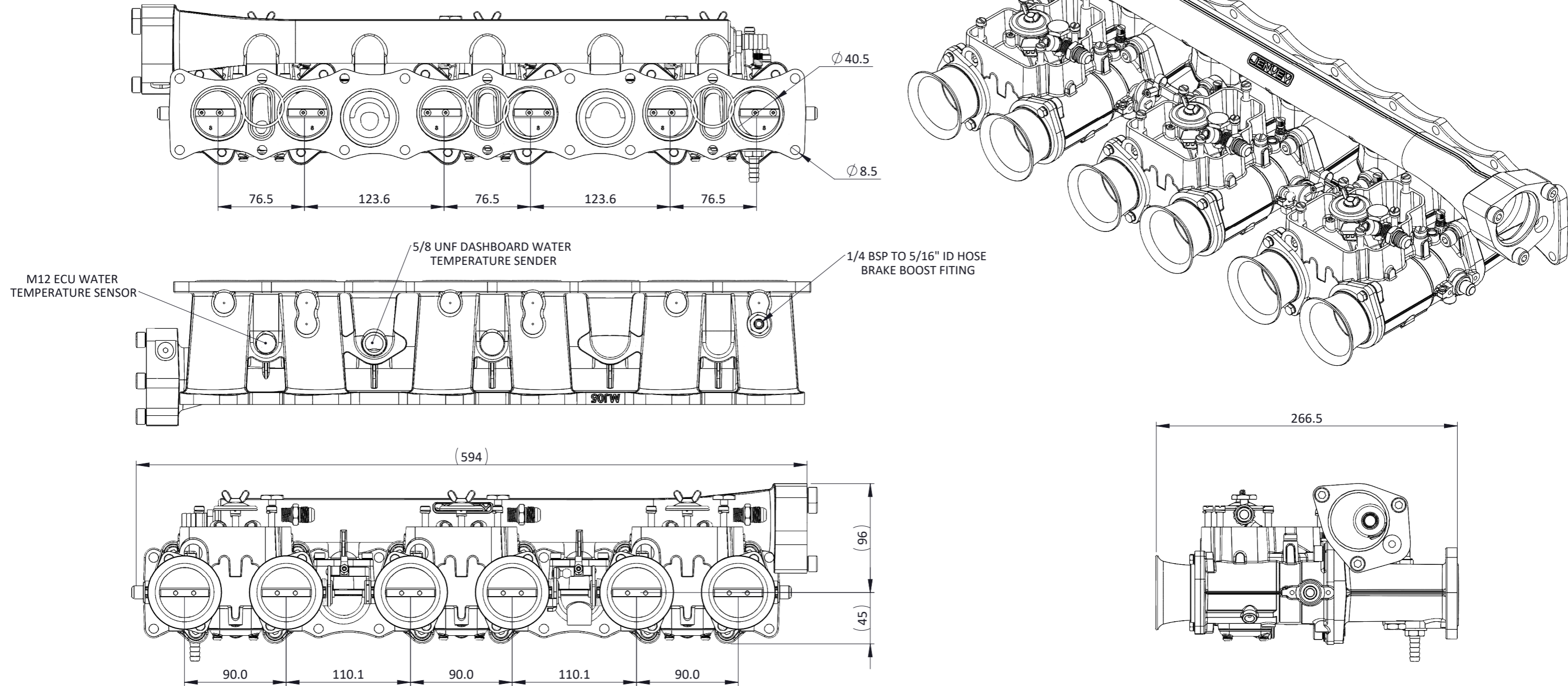

The Jenvey Jaguar XK6 manifold has been designed to suit both the E-Type Series 1 3.8L & 4.2L engines and the Series 2 4.2L engine, With inlet flanges to suit Jenvey DCOE Heritage and standard throttle bodies.

The Water manifold suits the series 1 4.2L thermostat housing (Series 2 housing will not fit underneath bonnet) and thermostat, and includes a heater outlet.

The manifold has features underneath for a take off for ECU water temperature sensor (M12), dashboard water temperature sender (5/8 UNF) & a spare undrilled water feature boss. Additionally it includes undrilled features on the underside of each runner for idle air/map take-offs & a 1/4 BSP to 5/16 ID hose fitting for brake boost.

The Heritage XK6 (CKJR05-TD) kit includes manifold and water manifold, TD45 Heritage throttle bodies, and Ø45x40mm air horns.

Frame: <a href="#">1 of 1</a>	
Version: <a href="#">2</a>	
Tel 01746 768810	© JENVEY DYNAMICS LTD. 2015
Web <a href="http://WWW.JENVEY.CO.UK">WWW.JENVEY.CO.UK</a>	